



**WHITE-RODGERS**

## 760 Series

Electrodes

### INSTALLATION INSTRUCTIONS

**Operator: Save these instructions for future use!**

**FAILURE TO READ AND FOLLOW ALL INSTRUCTIONS CAREFULLY BEFORE INSTALLING OR OPERATING THIS CONTROL COULD CAUSE PERSONAL INJURY AND/OR PROPERTY DAMAGE.**

#### DESCRIPTION

The 760 series electrodes are made in various configurations to meet the specific requirements of different applications. Depending on electrode design, they may be used for spark ignition, flame sensing or a combination of both.

These electrodes are not universal replacements. They can only be used to replace the identical type in applications where it was originally installed by the equipment manufacturer. If the electrode you are replacing is not the same type number, contact the original equipment manufacturer (OEM) for a suggested replacement.

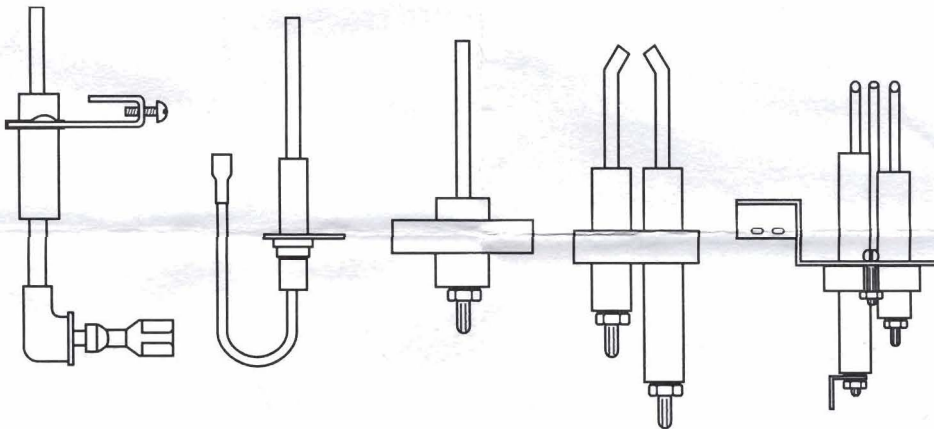

TYPICAL ELECTRODE ASSEMBLIES

#### PRECAUTIONS

THESE CONTROLS MUST BE INSTALLED BY A QUALIFIED INSTALLER.

All wiring must conform to local and national electrical codes and ordinances.

##### **WARNING**

Do not use on circuits exceeding specified voltages. Higher voltages will damage control and could cause shock or fire hazard.

Shut off main gas to heating system until installation is complete.

##### **CAUTION**

To prevent electrical shock and/or equipment damage, disconnect electric power to system at main fuse or circuit breaker box until installation is complete.

Label all wires prior to disconnection when servicing controls. Wiring errors can cause improper and dangerous operation.

Following installation or replacement, follow appliance manufacturers' recommended installation/service instructions to insure proper operation.



WHITE-RODGERS DIVISION  
EMERSON ELECTRIC CO.  
9797 REAVIS ROAD  
ST. LOUIS, MO 63123-5398  
(314) 577-1300 FAX (314) 577-1517

Printed in U.S.A.

PART NO. 37-5636A

9645

## INSTALLATION

---

If the equipment manufacturer has provided installation instructions, follow those instructions. If none are available, use the following general replacement instructions as a guideline.

### CAUTION

**On assemblies with three electrodes, do not disassemble ground plate from electrode assembly. This could change the factory set gap causing poor ignition.**

1. Shut off electric power and gas supply to the heater or device until installation is complete.
2. Remove existing electrode assembly. Be sure to label all wires before disconnecting. This will help when reconnecting leads to the new electrode assembly.
3. Install new electrode assembly. Make sure that new electrode is in the same position relative to the burner as the old electrode. Attach using screws or hardware previously removed. Connect all wires.
4. Turn on gas and electrical power to the system. Check the system for proper operation. Follow the appliance manufacturer's recommended installation and/or service instructions to insure proper operation.